

Lawnmowers

Lawnmower engines need regular maintenance as covered in the rest of this course especially:

- Air filter - clean or replace. These engines work in very dusty conditions.
- Fuel filters – clean
- Engine oil change (4 stroke)
- Spark plug – clean and gap
- Clean grass and dust from cooling fins and around the fuel tap and carburettor



In addition, lawn mowers also need the following maintenance.

- Motor controls and mountings
- Clean mower body
- Replace or sharpen blades.

Always follow the makers booklet for the way to do things and the parts you need.

Motor controls and mounts

Check all nuts, bolts and mountings – keep them tight.

Oil and/or clean controls and cables – such as throttle, cutting height adjusters

Mower body

Clean dirt and grass from the top surface around the engine.



Clean under the body:

- Remove spark plug lead from the plug – to make sure the engine cannot start.
- Turn the mower on its side – be careful of oil and dipstick on 4-strokes
- Scrape off all dirt and grass with a piece of wood or an old screw driver.
- Finish off with a stiff brush or a water hose if you have one.

Check the cutting blades are tight and not damaged – see next section

Clean old grass from around the wheels.

Cutting blades

Rotary lawn mowers have two or four cutting blades that spin around under the body.

Two blades on a bar like this:

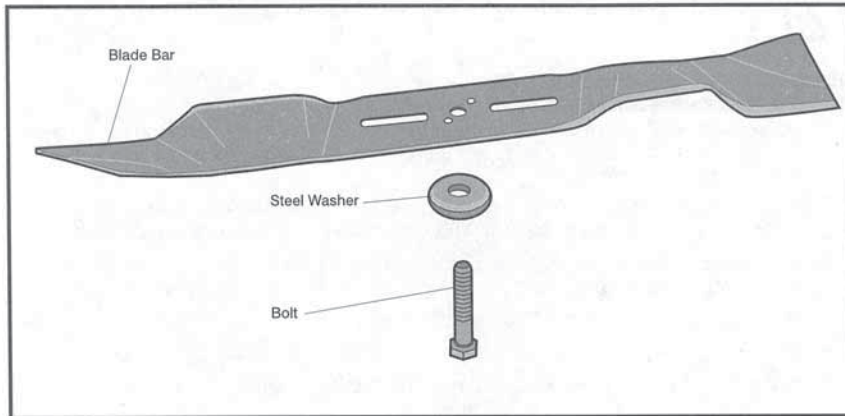

Or, four blades like this – bolted to a disc:

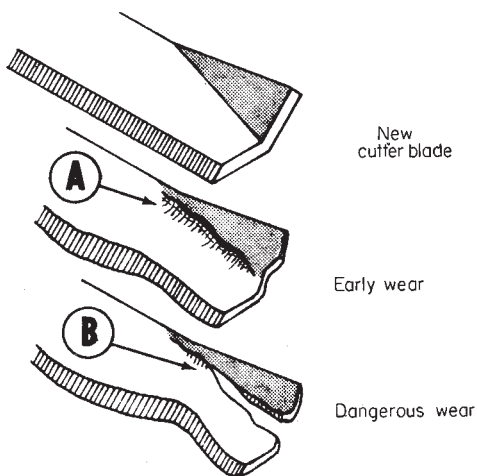
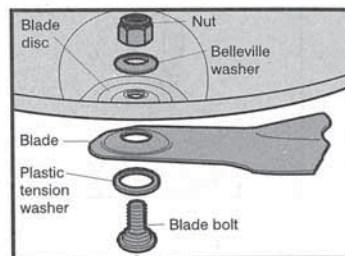

Damaged or loose blades are VERY dangerous as they can break or fly-off at great speed.

Damaged blades will also make the mower shake or vibrate because they are not in balance. The vibration may damage the engine crank-shaft if you use the mower like that for too long.

Blunt or worn-out blades will not cut grass well.

Always check the blades for damage if you hit something hard while you are mowing.

Changing blades

Mower makers recommend that you change blades as a set. This makes sure the mower keeps in balance.

Use the correct size, shape and weight of blade for your model of mower.

Remove the spark plug lead from the plug - to make sure the engine cannot start.

Turn the mower on its side – be careful of oil and dipstick on 4-strokes

Hold the blade with a cloth – or the disc on 4-blade mowers- to stop the engine turning

Undo the retaining bolt(s)

Take off the blade and replace with a new one

Make sure you put back all the bolts and washers in the right way.

Sharpening blades

If the blades are blunt, you can sharpen them with a file, sharpening stone or a grinder.

DO NOT sharpen damaged, cracked or broken blades. They are very dangerous!

Sharpen in the shape shown in the picture

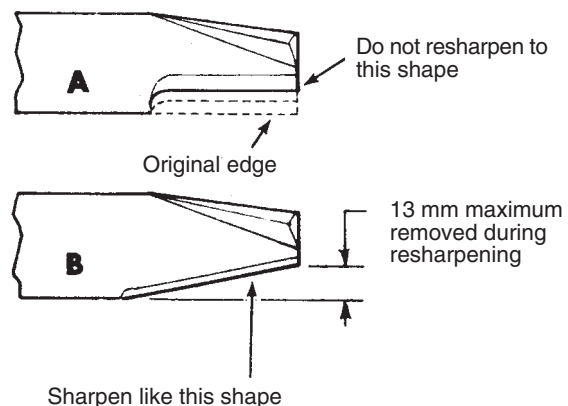

Blade balance

As you sharpen, check the balance of the blade-bar type, like this:

Put a straight thin bar or pin through the mounting hole – it should balance.

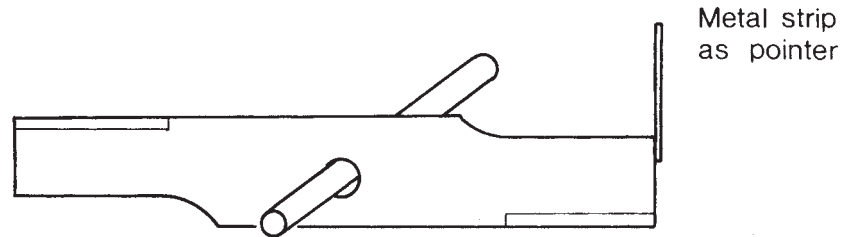

If one side drops down–

check that both sides are the same length

if not, file a little off the long end until they are the same.

Recheck balance

If one side still drops–

File off metal from the **back** of the heavy end

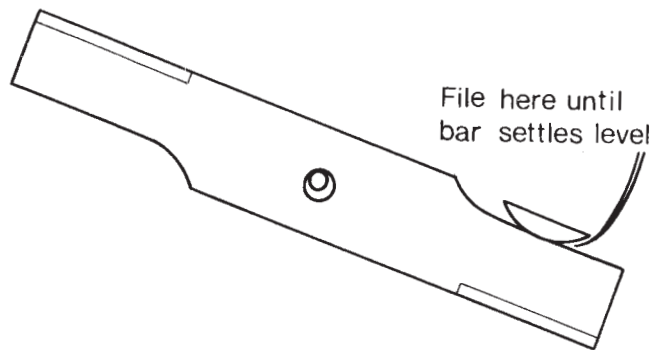

The better you get the balance, the smoother the engine will run.